



TJF1052i

Galvanically isolated high-speed CAN transceiver

Rev. 3 — 20 May 2016

Product data sheet

1. General description

The TJF1052i is a high-speed CAN transceiver that provides a galvanically isolated interface between a Controller Area Network (CAN) protocol controller and the physical two-wire CAN bus. The TJF1052i is specifically targeted at industrial applications, where galvanic isolation barriers are needed between the high- and low-voltage parts.

Safety: Isolation is required for safety reasons, eg. to protect humans from electric shock or to prevent the electronics being damaged by high voltages.

Signal integrity: The isolator uses proprietary capacitive isolation technology to transmit and receive CAN signals. This technology enables more reliable data communications in noisy environments, such as electric pumps, elevators or industrial equipment.

Performance: The transceiver is designed for high-speed CAN applications, supplying the differential transmit and receive capability to a CAN protocol controller in a microcontroller. Integrating the galvanic isolation along with the transceiver in the TJF1052i removes the need for stand-alone isolation. It also improves reliability and system performance parameters such as loop delay.

The TJF1052i belongs to the third generation of high-speed CAN transceivers from NXP Semiconductors, offering significant improvements over first- and second-generation devices. It offers improved ElectroMagnetic Compatibility (EMC) and ElectroStatic Discharge (ESD) performance, and also features ideal passive behavior to the CAN bus when the transceiver supply voltage is off.

The TJF1052i implements the CAN physical layer as defined in the current ISO11898 standard (ISO11898-2:2003). Pending the release of ISO11898-2:2016 including CAN FD and SAE J2284-4/5, additional timing parameters defining loop delay symmetry are specified. This implementation enables reliable communication in the CAN FD fast phase at data rates up to 5 Mbit/s.

The TJF1052i is an excellent choice for all types of industrial CAN networks where isolation is required for safety reasons or to enhance signal integrity in noisy environments.

2. Features and benefits

2.1 General

- Isolator and Transceiver integrated into a single SO16 package, reducing board space
- ISO 11898-2:2003 compliant
- Timing guaranteed for data rates up to 5 Mbit/s in the CAN FD fast phase
- Flawless cooperation between the Isolator and the Transceiver



- ◆ Fewer components improves reliability in applications
- ◆ Guaranteed performance (eg. max loop delay <220 ns)
- Electrical transient immunity of 45 kV/μs (typ)
- Suitable for use in 12 V and 24 V systems; compatible with 3 V to 5 V microcontrollers
- Bus common mode voltage (V_{cm}) = ±25 V
- Low ElectroMagnetic Emission (EME) and high ElectroMagnetic Immunity (EMI)
- Dark green product (halogen free and Restriction of Hazardous Substances (RoHS) compliant)

2.2 Power management

- Functional behavior predictable under all supply conditions
- Transceiver disengages from the bus when not powered up (zero load)

2.3 Protection

- Up to 5 kV (RMS) rated isolation
- Three versions available (1 kV, 2.5 kV and 5 kV)
- Voltage compliant with UL 1577, IEC 61010 and IEC 60950
- 5 kV (RMS) rated isolation voltage compliant with UL 1577, IEC 61010 and IEC 60950
- High ESD handling capability on the bus pins
- Transmit Data (TXD) dominant time-out function
- Undervoltage detection on supply pins

3. Quick reference data

Table 1. Quick reference data

Symbol	Parameter	Conditions	Min	Typ	Max	Unit
I _{DD1}	supply current 1	V _{TXD} = 0 V; bus dominant	-	-	2.6	mA
		V _{TXD} = V _{DD1} ; bus recessive	-	-	5.6	mA
I _{DD2}	supply current 2	V _{TXD} = 0 V; bus dominant; 60 Ω load	-	-	70	mA
		V _{TXD} = V _{DD1} ; bus recessive	-	-	10	mA
V _{uvd(swoff)(VDD2)}	switch-off undervoltage detection voltage on pin V _{DD2}		1.3	-	2.7	V
V _{ESD}	electrostatic discharge voltage	IEC 61000-4-2 at pins CANH and CANL	-8	-	+8	kV
V _{CANH}	voltage on pin CANH		-58	-	+58	V
V _{CANL}	voltage on pin CANL		-58	-	+58	V
T _{vj}	virtual junction temperature		-40	-	+125	°C
T _{amb}	ambient temperature		-40	-	+105	°C

4. Ordering information

Table 2. Ordering information

Type number	Package		Version
	Name	Description	
TJF1052IT/5 TJF1052IT/2 TJF1052IT/1	SO16	plastic small outline package; 16 leads; body width 7.5 mm	SOT162-1

Table 3. Voltage ratings

Type number	Rated insulation voltage according to UL 1577, IEC 61010 and IEC 60950
TJF1052IT/5	5 kV (RMS)
TJF1052IT/2	2.5 kV (RMS)
TJF1052IT/1	1 kV (RMS)

5. Block diagram

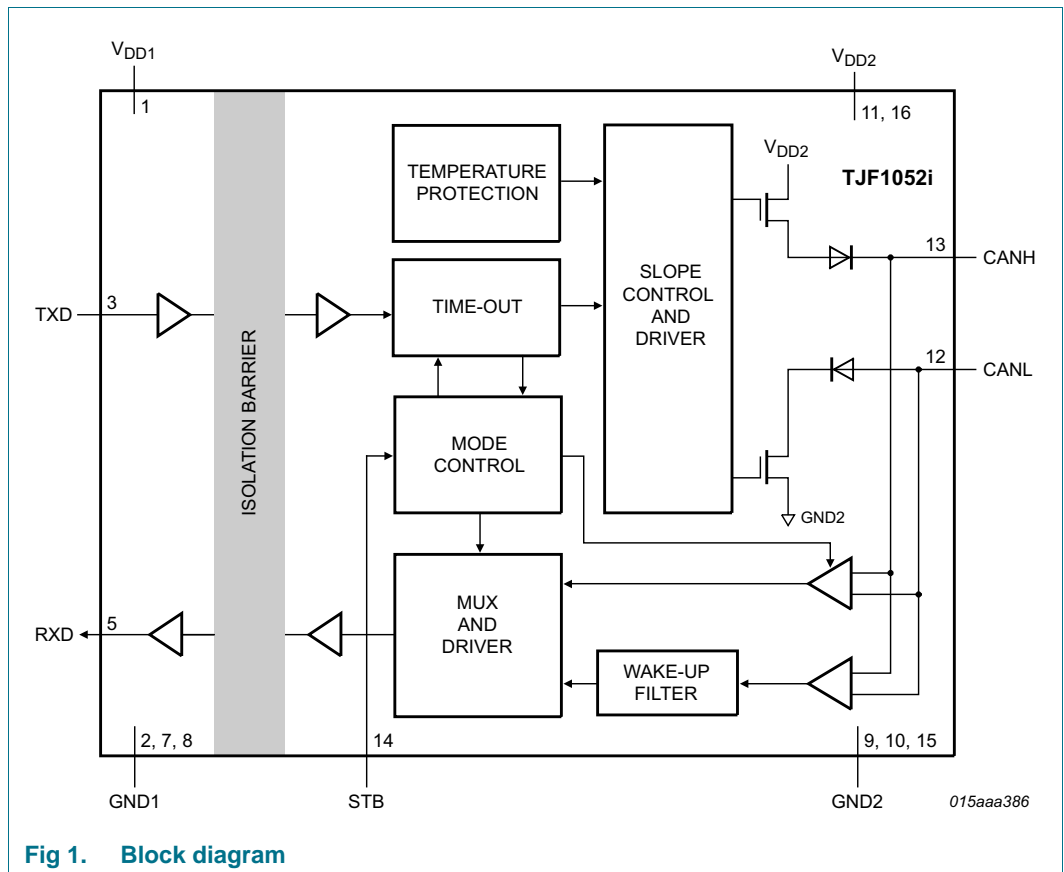

Fig 1. Block diagram

6. Pinning information

6.1 Pinning

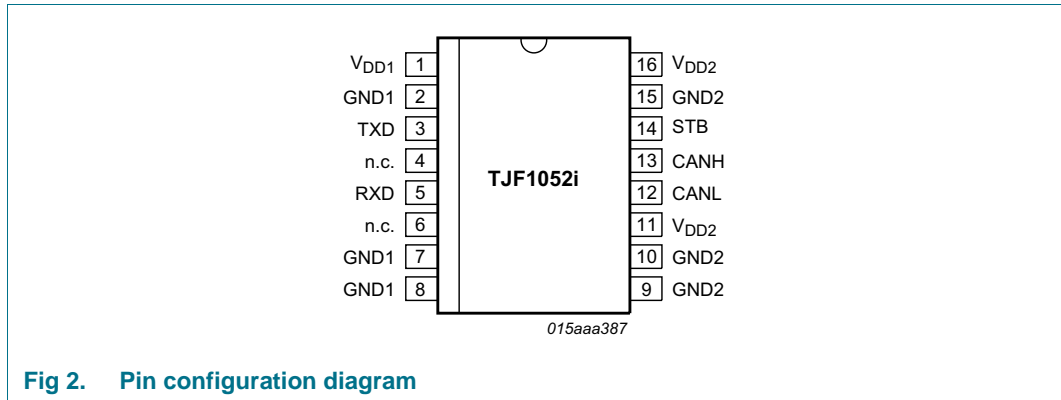

Fig 2. Pin configuration diagram

6.2 Pin description

Table 4. Pin description

Symbol	Pin	Description
V _{DD1}	1	supply voltage 1
GND1	2	ground supply 1 ^[1]
TXD	3	transmit data input
n/c	4	not connected
RXD	5	receive data output; reads out data from the bus lines
n/c	6	not connected
GND1	7	ground supply 1 ^[1]
GND1	8	ground supply 1 ^[1]
GND2	9	ground supply 2 ^[1]
GND2	10	ground supply 2 ^[1]
V _{DD2}	11	supply voltage 2
CANL	12	LOW-level CAN bus line
CANH	13	HIGH-level CAN bus line
STB	14	Standby mode control input ^[2]
GND2	15	ground supply 2 ^[1]
V _{DD2}	16	supply voltage 2

[1] All GND1 pins (pins 2, 7 and 8) should be connected together and to ground domain 1. All GND2 pins (pins 9, 10 and 15) should be connected together and to ground domain 2. Refer to the application notes for further information.

[2] Setting STB HIGH disables the CAN bus connection.

7. Functional description

7.1 Operation

7.1.1 Normal mode

During normal operation, the TJF1052i transceiver transmits and receives data via bus lines CANH and CANL (see [Figure 1](#) for the block diagram). The differential receiver converts the analog data on the bus lines into digital data, which is output on pin RXD. The slopes of the output signals on the bus lines are controlled internally and are optimized in a way that guarantees the lowest possible EME.

The isolator used in the TJF1052i is an AC device that employs on-off keying to guarantee the DC output state at all times. The states of TXD, RXD and the CAN bus at start-up, shut-down and during normal operation are described in [Table 5](#).

Care should be taken regarding power sequencing if the device is used in networks that support remote wake-up (see [Section 12 “Application information”](#)).

Table 5. Input/output states at start-up, shut-down and during normal operation

TXD	RXD	V _{DD1}	V _{DD2}	CAN	Comments
H	H	>V _{uvd} (V _{DD1})	>V _{uvd(stb)} V _{DD2}	recessive	Normal mode operation
L	L	>V _{uvd} (V _{DD1})	>V _{uvd(stb)} V _{DD2}	dominant	Normal mode with TXD dominant time-out active
X	X	unpowered	>V _{uvd(stb)} V _{DD2}	dominant	dominant after V _{DD1} power loss until TXD dominant timeout; recessive while V _{DD2} is ramping up from an unpowered state
X	L	>V _{uvd} (V _{DD1})	unpowered	disconnected	RXD transitions L-to-H when V _{DD2} restored

7.1.2 Standby mode

The TJF1052i cannot transmit or receive regular CAN messages in Standby mode. Only the isolator and low-power CAN receiver are active, monitoring the bus lines for activity. The bus wake-up filter ensures that only bus dominant and bus recessive states that persist longer than $t_{\text{fltr(wake)bus}}$ are reflected on the RXD pin. To reduce current consumption, the CAN bus is terminated to GND and not biased to $V_{DD2}/2$ as in Normal mode.

Standby mode is selected by setting pin STB HIGH. The TJF1052i also switches to Standby mode when an undervoltage is detected on V_{DD2} ($V_{\text{uvd(swoff)}}(V_{DD2}) < V_{DD2} < V_{\text{uvd(stb)}}(V_{DD2})$; [Section 7.2.2](#)). An internal pull-up ensures that Standby mode is selected by default when pin STB is not connected.

In Standby mode:

- The CAN transmitter is off
- The normal CAN receiver is off
- The low-power CAN receiver is active
- CANH and CANL are biased to GND
- The signal received at the low-power CAN receiver is reflected on pin RXD
- V_{DD2} undervoltage detection is active

The isolation function of the TJF1052i is not disabled in Standby mode. Overall quiescent current is not reduced significantly in this mode. The TJF1052i is not designed to support CAN bus wake-up functionality with very low quiescent currents.

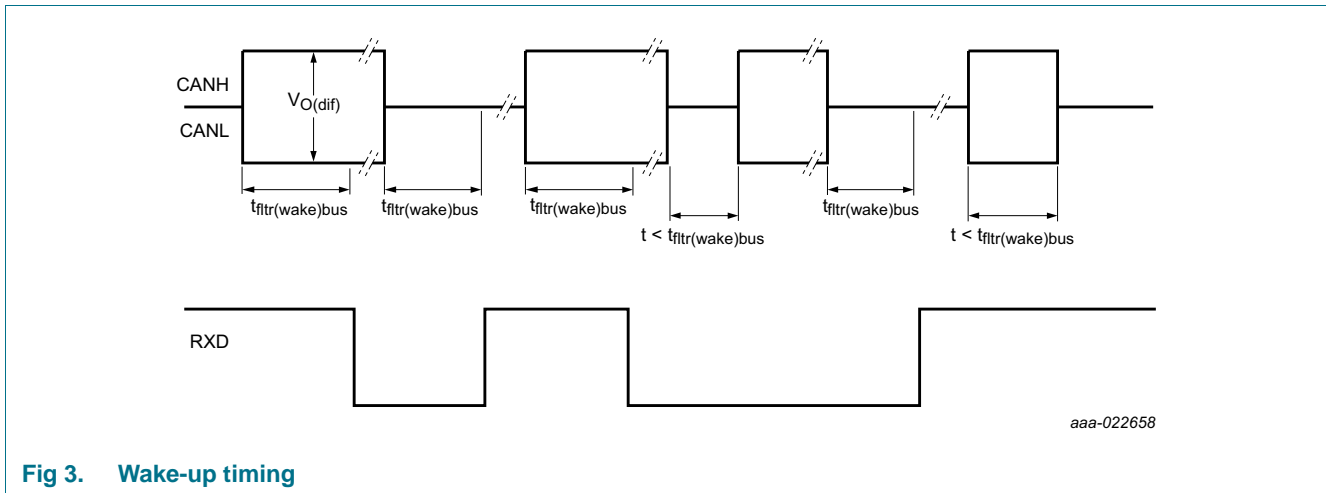

Fig 3. Wake-up timing

7.2 Fail-safe features

7.2.1 TXD dominant time-out function

A 'TXD dominant time-out' timer is started when pin TXD goes LOW. If the LOW state on TXD persists for longer than $t_{to(dom)TXD}$, the transmitter is disabled, releasing the bus lines to recessive state. This function prevents a hardware and/or software application failure from driving the bus lines to a permanent dominant state (blocking all network communications). The TXD dominant time-out timer is reset by a positive edge on TXD. The TXD dominant time-out time also defines the minimum possible bit rate of 40 kbit/s.

7.2.2 Undervoltage protection: V_{DD2}

If the voltage on pin V_{DD2} falls below the standby threshold, $V_{uvd(stb)}(V_{DD2})$, the transceiver switches to Standby mode. The TJF1052i will remain in Standby mode until V_{DD2} rises above $V_{uvd(stb)}(V_{DD2})$ (max). The low-power receiver continues to monitor the bus while the TJF1052i is in Standby mode. Data on the bus is still reflected onto RXD, but the transfer speed is reduced.

If the voltage on V_{DD2} falls below the switch-off threshold, $V_{uvd(swoff)}(V_{DD2})$, the transceiver switches off and disengages from the bus (zero load). It is guaranteed to switch on again in Standby mode when V_{DD2} rises above $V_{uvd(swoff)}(V_{DD2})$ (max).

7.2.3 Undervoltage protection: V_{DD1}

If the voltage on pin V_{DD1} falls below the undervoltage detection threshold, $V_{uvd}(V_{DD1})$, the CAN bus switches to dominant state and the TXD dominant timeout timer is started. RXD will not go high again until the supply voltage has been restored on V_{DD1} ($V_{DD1} > V_{uvd}(V_{DD1})$).

7.2.4 Overtemperature protection

The output drivers are protected against overtemperature conditions. If the virtual junction temperature exceeds the shutdown junction temperature, $T_{j(sd)}$, the output drivers are disabled. They are enabled again when the virtual junction temperature falls below $T_{j(sd)}$ and TXD is HIGH. Including the TXD condition ensures that output driver oscillation due to temperature drift is avoided.

7.3 Insulation characteristics and safety-related specifications

Table 6. Isolator characteristics

Symbol	Parameter	Conditions	Min	Typ	Max	Unit
$d_{L(I01)}$	minimum air gap		[1] 8.6	-	-	mm
$d_{L(I02)}$	minimum external tracking		[2] 8.1	-	-	mm
R_{ins}	insulation resistance	$T_A = 125\text{ °C}$	[3] 100	-	-	$G\Omega$
		$T_A = 150\text{ °C}$	[3] 10	-	-	$G\Omega$
-	pollution degree	-	2	-	-	-
-	material group (IEC 60664)		2	-	-	-

- [1] Based on the measured data in the package outline. $d_{L(I01)}$ is the clearance distance. Note that the clearance distance cannot be larger than the creepage distance ($d_{L(I02)}$).
- [2] Based on the measured data in the package outline. $d_{L(I02)}$ is the creepage distance. According to IEC 60950-1, normative annex F (also IEC60664 chapter 6.2, Example 11), the effective minimum external tracking is 1.0 mm less due to the presence of an intervening, unconnected conductive part.
- [3] Guaranteed by design at a voltage differential of 500 V with the pins on each side of the isolation barrier connected together, simulating a 2-pin device.

Table 7. Working voltages and isolation

Insulation Characteristics				
Parameter	Standard	TJA1052i/1	TJA1052i/2	TJA1052i/5
max. working insulation voltage per IEC 60664 (V_{IORM}) ^[1]	IEC 60664	300 V_{RMS}	450 V_{RMS}	800 V_{RMS}
		420 V_{peak}	630 V_{peak}	1120 V_{peak}
max. transient overvoltage per IEC 60664 (V_{IOTM}) ^[2]	$t_{TEST} = 1.2/50 \mu s$ (certification) IEC 60664	2500 V_{peak}	4000 V_{peak}	6000 V_{peak}
rated insulation voltage per UL 1577 (V_{ISO})	UL 1577			
	$t_{TEST} = 60 s$ (qualification)	1000 V_{RMS}	2500 V_{RMS}	5000 V_{RMS}
	$t_{TEST} = 1 s$ (production)	1200 V_{RMS}	3000 V_{RMS}	6000 V_{RMS}
Insulation classification in terms of Overvoltage Category ^[3]				
Insulation type	Max. working voltage	TJA1052i/1	TJA1052i/2	TJA1052i/5
basic insulation ^[4]	$\leq 150 V_{RMS}$	I - III	I - IV	I - IV
	$\leq 300 V_{RMS}$	I - II	I - III	I - IV
	$\leq 600 V_{RMS}$	I	I - II	I - III
	$\leq 1000 V_{RMS}$	-	-	I - II
reinforced insulation ^[4]	$\leq 150 V_{RMS}$	I - II	I - III	I - IV
	$\leq 300 V_{RMS}$	I	I - II	I - III
	$\leq 600 V_{RMS}$	-	I	I - II
	$\leq 1000 V_{RMS}$	-	-	I

- [1] The working voltage is the input-to-output voltage that can be applied without time limit. Which TJF1052i variant should be selected depends on the overvoltage category and the related insulation voltage.
- [2] UL stress test is performed at higher than IEC-specified levels.
- [3] Based on transient overvoltages as indicated in IEC60664; creepage and clearance distances not taken into account.
- [4] Reinforced insulation should have an impulse withstand voltage one step higher than that specified for basic insulation.

Table 8. Safety approvals

Standard	File number
IEC 60950	CB NL-33788
IEC 61010-1 2nd Edition	CB NL-33789
UL1577	20131213-E361297

8. Limiting values

Table 9. Limiting values

In accordance with the Absolute Maximum Rating System (IEC 60134). All voltages and currents are referenced to GND2 unless otherwise specified.

Symbol	Parameter	Conditions	Min	Max	Unit
V _x	voltage on pin x ^[1]	on pins CANH, CANL	-58	+58	V
		on pin V _{DD1} ^[2] , V _{DD2}	-0.3	+6.0	V
		on pin STB	-0.3	V _{DD2} + 0.3	V
V _I	input voltage	on pin TXD ^[2]	-0.3	V _{DD1} + 0.3	V
V _O	output voltage	on pin RXD ^[2]	-0.3	V _{DD1} + 0.3	V
I _O	output current	on pin RXD ^[2]	-	10	mA
V _(CANH-CANL)	voltage between pin CANH and pin CANL		-27	+27	V
V _{trt}	transient voltage	on pins CANH and CANL ^[3]			
		pulse 1	-100	-	V
		pulse 2a	-	75	V
		pulse 3a	-150	-	V
		pulse 3b	-	100	V
V _{ESD}	electrostatic discharge voltage	IEC 61000-4-2 (150 pF, 330 Ω) ^[4]			
		at pins CANH and CANL	-8	+8	kV
		Human Body Model (HBM); 100 pF, 1.5 kΩ ^[5]			
		at pins CANH and CANL ^[6]	-8	+8	kV
		at any other pin	-4	+4	kV
		Machine Model (MM); 200 pF, 0.75 μH, 10 Ω ^[7]			
		at any pin	-300	+300	V
		Charged Device Model (CDM); field Induced charge; 4 pF ^[8]			
at corner pins	-750	+750	V		
at any pin	-500	+500	V		
T _{vj}	virtual junction temperature	^[9]	-40	+125	°C
T _{amb}	ambient temperature		-40	+105	°C
T _{stg}	storage temperature	^[10]	-65	+150	°C

[1] The device can sustain voltages up to the specified values over the product lifetime, provided applied voltages (including transients) never exceed these values.

[2] Referenced to GND1.

[3] According to IEC TS 62228 (2007), Section 4.2.4; parameters for standard pulses defined in ISO7637 part 2: 2004-06.

[4] According to IEC TS 62228 (2007), Section 4.3; DIN EN 61000-4-2.

[5] According to AEC-Q100-002.

[6] ±8 kV to GND2 and V_{DD2}; ±6 kV to GND1.

[7] According to AEC-Q100-003.

[8] According to AEC-Q100-011 Rev-C1. The classification level is C4B.

[9] An alternative definition of virtual junction temperature is: $T_{vj} = T_{amb} + P \times R_{th(vj-a)}$, where $R_{th(vj-a)}$ is a fixed value used in the calculation of T_{vj} . The rating for T_{vj} limits the allowable combinations of power dissipation (P) and ambient temperature (T_{amb}).

[10] If UL compliance is required, the maximum storage temperature is limited to 130 °C.

9. Thermal characteristics

Table 10. Thermal characteristics

According to IEC 60747-1.

Symbol	Parameter	Conditions	Value	Unit
$R_{th(vj-a)}$	thermal resistance from virtual junction to ambient	in free air	100	K/W

10. Static characteristics

Table 11. Static characteristics

$T_{vj} = -40\text{ }^{\circ}\text{C}$ to $+125\text{ }^{\circ}\text{C}$; $V_{DD1} = 3.0\text{ V}$ to 5.25 V with respect to GND1; $V_{DD2} = 4.75\text{ V}$ to 5.25 V with respect to GND2 unless otherwise specified. Positive currents flow into the IC. All voltages and currents are referenced to GND2 unless otherwise specified^[1].

Symbol	Parameter	Conditions	Min	Typ	Max	Unit
DC supplies; pin V_{DD1} and V_{DD2}						
I_{DD1}	supply current 1	$V_{DD1} = 3\text{ V}$ to 5 V ^[2] ; $V_{DD2} = 5\text{ V}$; $V_{TXD} = 0\text{ V}$ ^[2] ; bus dominant	-	-	2.6	mA
		$V_{DD1} = 3\text{ V}$ to 5 V ^[2] ; $V_{DD2} = 5\text{ V}$; $V_{TXD} = V_{DD1}$ ^[2] ; bus recessive	-	-	5.6	mA
I_{DD2}	supply current 2	$V_{DD1} = 3\text{ V}$ to 5 V ^[2] ; $V_{DD2} = 5\text{ V}$; $V_{TXD} = 0\text{ V}$ ^[2] ; bus dominant; $R_L = 60\ \Omega$	-	-	67.6	mA
		$V_{DD1} = 3\text{ V}$ to 5 V ^[2] ; $V_{DD2} = 5\text{ V}$; $V_{TXD} = V_{DD1}$ ^[2] ; bus recessive; $V_{STB} = 0\text{ V}$	-	-	13.1	mA
		$V_{DD1} = 3\text{ V}$ to 5 V ^[2] ; $V_{DD2} = 5\text{ V}$; $V_{TXD} = V_{DD1}$ ^[2] ; bus recessive; $V_{STB} = 5\text{ V}$	-	-	5.6	mA
$V_{uvd(stb)(VDD2)}$	standby undervoltage detection voltage on pin V _{DD2}		3.5	-	4.75	V
$V_{uvd(swoff)(VDD2)}$	switch-off undervoltage detection voltage on pin V _{DD2}		1.3	-	2.7	V
$V_{uvd(VDD1)}$	undervoltage detection voltage on pin V _{DD1}	^[2]	1.3	-	2.7	V
V_{uvhys}	undervoltage hysteresis voltage	on pin V _{DD1}	^[2] 40	-	100	mV
		on pin V _{DD2}	80	-	200	mV
CAN transmit data input; pin TXD						
V_{IH}	HIGH-level input voltage	^[2]	2.0	-	V_{DD1}	V
V_{IL}	LOW-level input voltage	^[2]	0	-	0.8	V
I_{LI}	input leakage current	^[2]	-10	-	+10	μA
CAN receive data output; pin RXD						
V_{OH}	HIGH-level output voltage	$I_{OH} = -4\text{ mA}$	^[2]	$V_{DD1} - 0.4$	-	V
V_{OL}	LOW-level output voltage	$I_{OL} = 4\text{ mA}$	^[2]	-	0.4	V
Standby mode control input; pin STB						
V_{IH}	HIGH-level input voltage		$0.7V_{DD2}$	-	$V_{DD2} + 0.3$	V

Table 11. Static characteristics ...continued

$T_{vj} = -40\text{ }^{\circ}\text{C}$ to $+125\text{ }^{\circ}\text{C}$; $V_{DD1} = 3.0\text{ V}$ to 5.25 V with respect to GND1; $V_{DD2} = 4.75\text{ V}$ to 5.25 V with respect to GND2 unless otherwise specified. Positive currents flow into the IC. All voltages and currents are referenced to GND2 unless otherwise specified^[1].

Symbol	Parameter	Conditions	Min	Typ	Max	Unit
V_{IL}	LOW-level input voltage		-0.3	-	$0.3V_{DD2}$	V
I_{IH}	HIGH-level input current	$V_{STB} = V_{DD2}$	-1	-	+1	μA
I_{IL}	LOW-level input current	$V_{STB} = 0\text{ V}$	-15	-	-1	μA
Bus lines; pins CANH and CANL						
$V_{O(\text{dom})}$	dominant output voltage	$V_{TXD} = 0\text{ V}$; $t < t_{to(\text{dom})TXD}$				
		pin CANH; $R_L = 50\ \Omega$ to $65\ \Omega$	2.75	3.5	4.5	V
		pin CANL; $R_L = 50\ \Omega$ to $65\ \Omega$	0.5	1.5	2.25	V
$V_{\text{dom(TX)sym}}$	transmitter dominant voltage symmetry	$V_{\text{dom(TX)sym}} = V_{DD2} - V_{\text{CANH}} - V_{\text{CANL}}$	-400	-	+400	mV
$V_{TX\text{sym}}$	transmitter voltage symmetry	$V_{TX\text{sym}} = V_{\text{CANH}} + V_{\text{CANL}}$; $f_{TXD} = 250\text{ kHz}$; $C_{\text{SPLIT}} = 4.7\text{ nF}$	^[3] ^[4] 0.9 V_{DD2}	-	1.1 V_{DD2}	V
$V_{O(\text{dif})}$	differential output voltage	dominant; Normal mode				
		$V_{TXD} = 0\text{ V}$; $t < t_{to(\text{dom})TXD}$; $R_L = 45\ \Omega$ to $70\ \Omega$	^[2] 1.5	-	3	V
		$V_{TXD} = 0\text{ V}$; $t < t_{to(\text{dom})TXD}$; $R_L = 2240\ \Omega$	^[2] 1.5	-	5	V
		recessive				
		Normal mode; $V_{TXD} = V_{DD1}$; no load	^[2] -50	-	+50	mV
		Standby mode; no load	-0.2	-	+0.2	V
$V_{O(\text{rec})}$	recessive output voltage	Normal mode; $V_{TXD} = V_{DD1}$; no load	^[2] 2	0.5 V_{DD2}	3	V
$V_{th(\text{RX})\text{dif}}$	differential receiver threshold voltage	Normal mode; $-25\text{ V} \leq V_{\text{CANL}} \leq +25\text{ V}$; $-25\text{ V} \leq V_{\text{CANH}} \leq +25\text{ V}$	0.5	-	0.9	V
		Standby mode; $-12\text{ V} \leq V_{\text{CANL}} \leq +12\text{ V}$; $-12\text{ V} \leq V_{\text{CANH}} \leq +12\text{ V}$	^[5] 0.4	-	1.15	V
$V_{\text{rec(RX)}}$	receiver recessive voltage	Normal mode; $-12\text{ V} \leq V_{\text{CANL}} \leq +12\text{ V}$; $-12\text{ V} \leq V_{\text{CANH}} \leq +12\text{ V}$	-3	-	0.5	V
$V_{\text{dom(RX)}}$	receiver dominant voltage	Normal mode; $-12\text{ V} \leq V_{\text{CANL}} \leq +12\text{ V}$; $-12\text{ V} \leq V_{\text{CANH}} \leq +12\text{ V}$	0.9	-	8.0	V
$V_{\text{hys(RX)dif}}$	differential receiver hysteresis voltage	$-25\text{ V} \leq V_{\text{CANL}} \leq +25\text{ V}$; $-25\text{ V} \leq V_{\text{CANH}} \leq +25\text{ V}$; Normal mode	-	165	-	mV
$I_{O(\text{sc})\text{dom}}$	dominant short-circuit output current	$V_{TXD} = 0\text{ V}$ ^[2] ; $t < t_{to(\text{dom})TXD}$; $V_{DD2} = 5\text{ V}$				
		pin CANH; $V_{\text{CANH}} = -3\text{ V}$ to $+40\text{ V}$	-100	-70	-40	mA
		pin CANL; $V_{\text{CANL}} = -3\text{ V}$ to $+40\text{ V}$	40	70	100	mA
$I_{O(\text{sc})\text{rec}}$	recessive short-circuit output current	Normal mode; $V_{TXD} = V_{DD1}$ ^[2] ; $V_{\text{CANH}} = V_{\text{CANL}} = -27\text{ V}$ to $+32\text{ V}$	-5	-	+5	mA

Table 11. Static characteristics ...continued

$T_{vj} = -40\text{ }^{\circ}\text{C}$ to $+125\text{ }^{\circ}\text{C}$; $V_{DD1} = 3.0\text{ V}$ to 5.25 V with respect to GND1; $V_{DD2} = 4.75\text{ V}$ to 5.25 V with respect to GND2 unless otherwise specified. Positive currents flow into the IC. All voltages and currents are referenced to GND2 unless otherwise specified^[1].

Symbol	Parameter	Conditions	Min	Typ	Max	Unit
I_L	leakage current	$V_{DD2} = 0\text{ V}$ or V_{DD2} shorted to GND via $47\text{ k}\Omega$; $V_{CANH} = V_{CANL} = 5\text{ V}$;	-3	-	+3	μA
R_i	input resistance		9	15	28	$\text{k}\Omega$
ΔR_i	input resistance deviation	between V_{CANH} and V_{CANL}	-3	-	+3	%
$R_{i(dif)}$	differential input resistance		19	30	52	$\text{k}\Omega$
$C_{i(cm)}$	common-mode input capacitance		[3]	-	20	pF
$C_{i(dif)}$	differential input capacitance		[3]	-	10	pF
Temperature detection						
$T_{j(sd)}$	shutdown junction temperature		[3] [6]	-	190	$^{\circ}\text{C}$

- [1] All parameters are guaranteed over the virtual junction temperature range by design. Factory testing uses correlated test conditions to cover the specified temperature and power supply voltage range.
- [2] Referenced to GND1.
- [3] Not tested in production; guaranteed by design.
- [4] The test circuit used to measure the bus output voltage symmetry (which includes C_{SPLIT}) is shown in [Figure 10](#).
- [5] Standby mode entered when V_{DD2} falls below $V_{uvd(stb)}(V_{DD2})$.
- [6] RXD is LOW during thermal shutdown.

11. Dynamic characteristics

Table 12. Dynamic characteristics

$T_{vj} = -40\text{ }^{\circ}\text{C}$ to $+125\text{ }^{\circ}\text{C}$; $V_{DD1} = 3.0\text{ V}$ to 5.25 V with respect to $GND1$; $V_{DD2} = 4.75\text{ V}$ to 5.25 V with respect to $GND2$ unless otherwise specified^[1].

Symbol	Parameter	Conditions	Min	Typ	Max	Unit
Transceiver timing; pins CANH, CANL, TXD and RXD; see Figure 4						
$t_{d(\text{TXD-busdom})}$	delay time from TXD to bus dominant	Normal mode	-	72	120	ns
$t_{d(\text{TXD-busrec})}$	delay time from TXD to bus recessive	Normal mode	-	97	120	ns
$t_{d(\text{busdom-RXD})}$	delay time from bus dominant to RXD	Normal mode	-	67	130	ns
$t_{d(\text{busrec-RXD})}$	delay time from bus recessive to RXD	Normal mode	-	72	130	ns
$t_{d(\text{TXDL-RXDL})}$	delay time from TXD LOW to RXD LOW	Normal mode	72	-	220	ns
$t_{d(\text{TXDH-RXDH})}$	delay time from TXD HIGH to RXD HIGH	Normal mode	72	-	220	ns
$t_{\text{bit}(\text{bus})}$	transmitted recessive bit width	$t_{\text{bit}(\text{TXD})} = 500\text{ ns}$	^[2] 435	-	530	ns
		$t_{\text{bit}(\text{TXD})} = 200\text{ ns}$	^[2] 155	-	210	ns
$t_{\text{bit}(\text{RXD})}$	bit time on pin RXD	$t_{\text{bit}(\text{TXD})} = 500\text{ ns}$	^[2] 400	-	550	ns
		$t_{\text{bit}(\text{TXD})} = 200\text{ ns}$	^[2] 120	-	220	ns
Δt_{rec}	receiver timing symmetry	$t_{\text{bit}(\text{TXD})} = 500\text{ ns}$	-65	-	+40	ns
		$t_{\text{bit}(\text{TXD})} = 200\text{ ns}$	-45	-	+15	ns
$t_{\text{to}(\text{dom})\text{TXD}}$	TXD dominant time-out time	$V_{\text{TXD}} = 0\text{ V}$; Normal mode	^[3] 0.3	1.7	5	ms
CMTI	common-mode transient immunity	$V_I = V_{DD1}$ or $V_I = 0\text{ V}$	^[4] 20	45	-	kV/ μs
t_{startup}	start-up time		^[5] -	-	500	μs
$t_{\text{ftr}(\text{wake})\text{bus}}$	bus wake-up filter time	Standby mode	0.5	1	3	μs

[1] All parameters are guaranteed over the virtual junction temperature range by design. Factory testing uses correlated test conditions to cover the specified temperature and power supply voltage range.

[2] See Figure 5.

[3] Referenced to $GND1$.

[4] V_I is the input voltage on TXD. See Figure 7 for test setup.

[5] The start-up time is the time from the application of power to valid data at the output. Guaranteed by design.

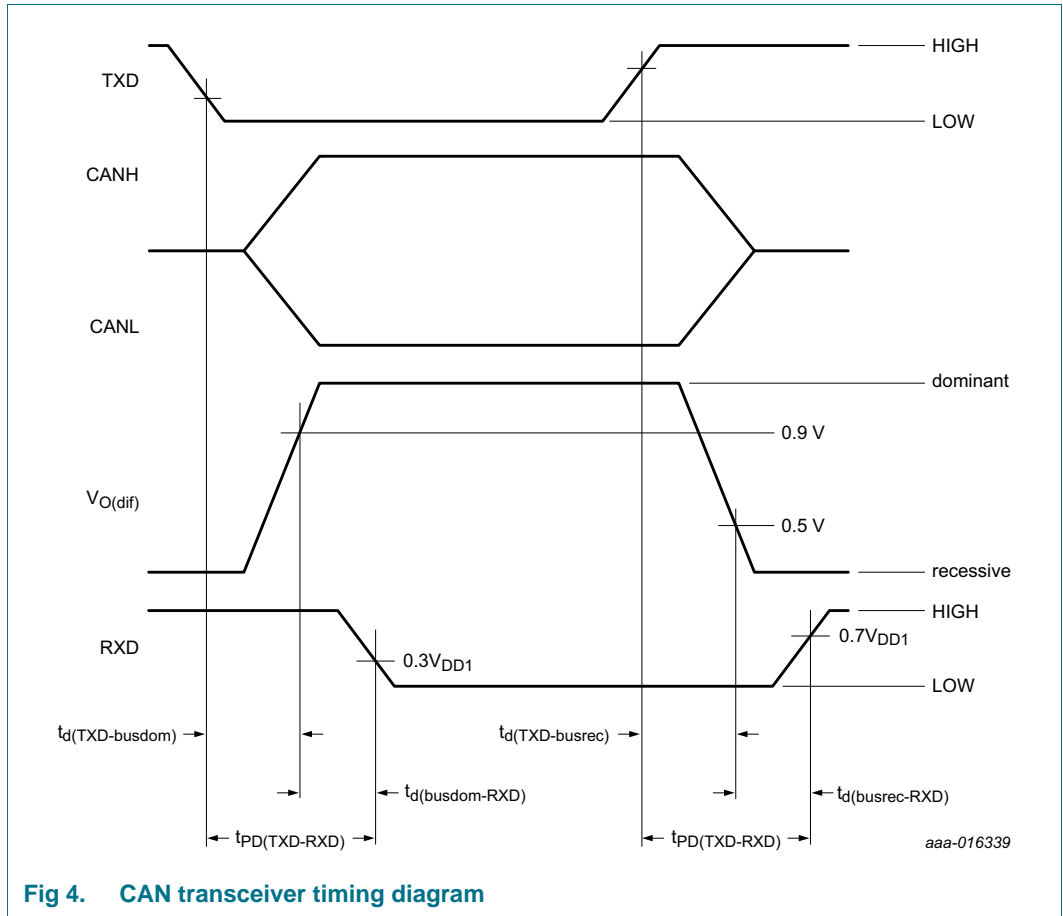

Fig 4. CAN transceiver timing diagram

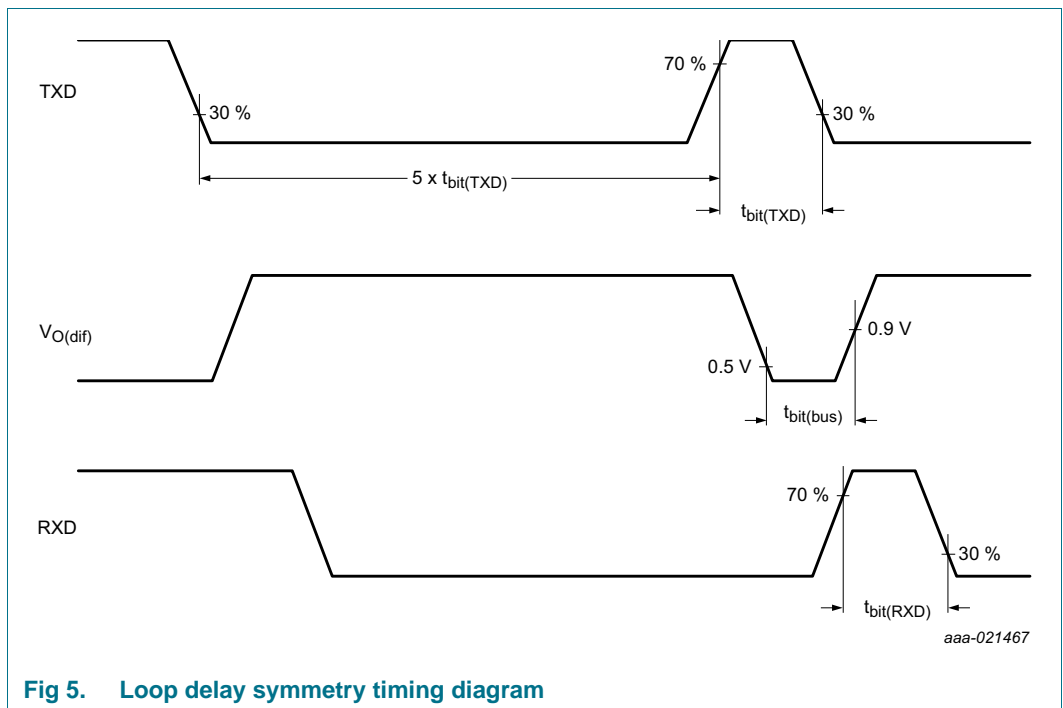

Fig 5. Loop delay symmetry timing diagram

12. Application information

Isolated CAN applications are becoming increasingly common in industrial automation processes. The TJF1052i is the ideal solution in applications that require an isolated CAN node. The device can also be used to isolate high-voltage on-demand pumps and motors in belt elimination projects.

If the TJF1052i is used in a HS-CAN network that supports remote bus wake-up, the power-down sequence of the supplies must be managed properly to avoid a dominant pulse on the CAN bus. V_{DD2} should pass the minimum undervoltage threshold ($V_{uvd(stb)}(V_{DD2})$ (min)) before V_{DD1} falls below its maximum undervoltage detection threshold ($V_{uvd}(V_{DD1})(max)$). Power-up sequencing can happen in any order.

Digital inputs and outputs are 3 V compliant, allowing the TJF1052i to interface directly with 3 V and 5 V microcontrollers.

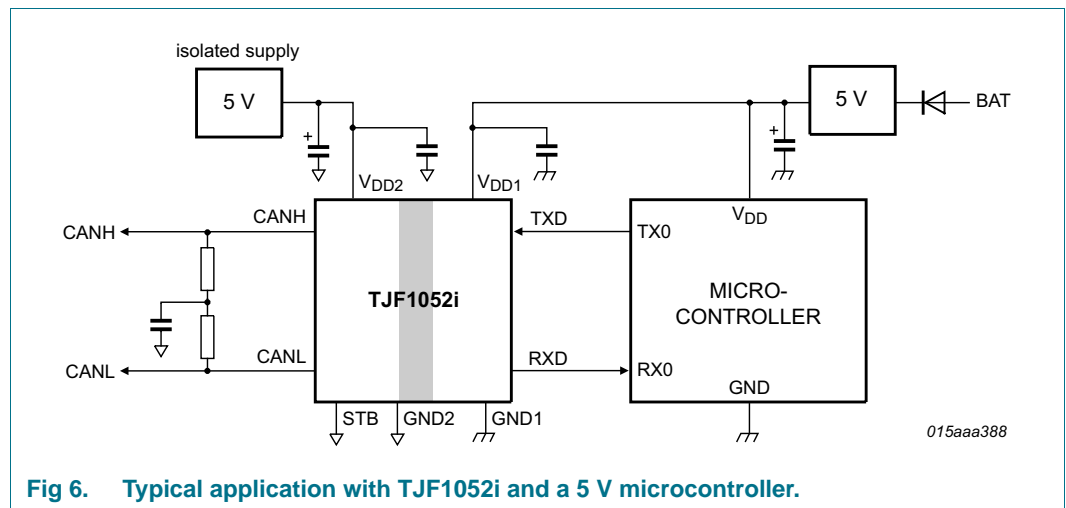

Fig 6. Typical application with TJF1052i and a 5 V microcontroller.

12.1 Application hints

Further information on the application of the TJF1052i can be found in NXP application hints *AH1301 Application Hints - TJA1052i Galvanic Isolated High Speed CAN Transceiver*.

13. Test information

13.1 Test circuits

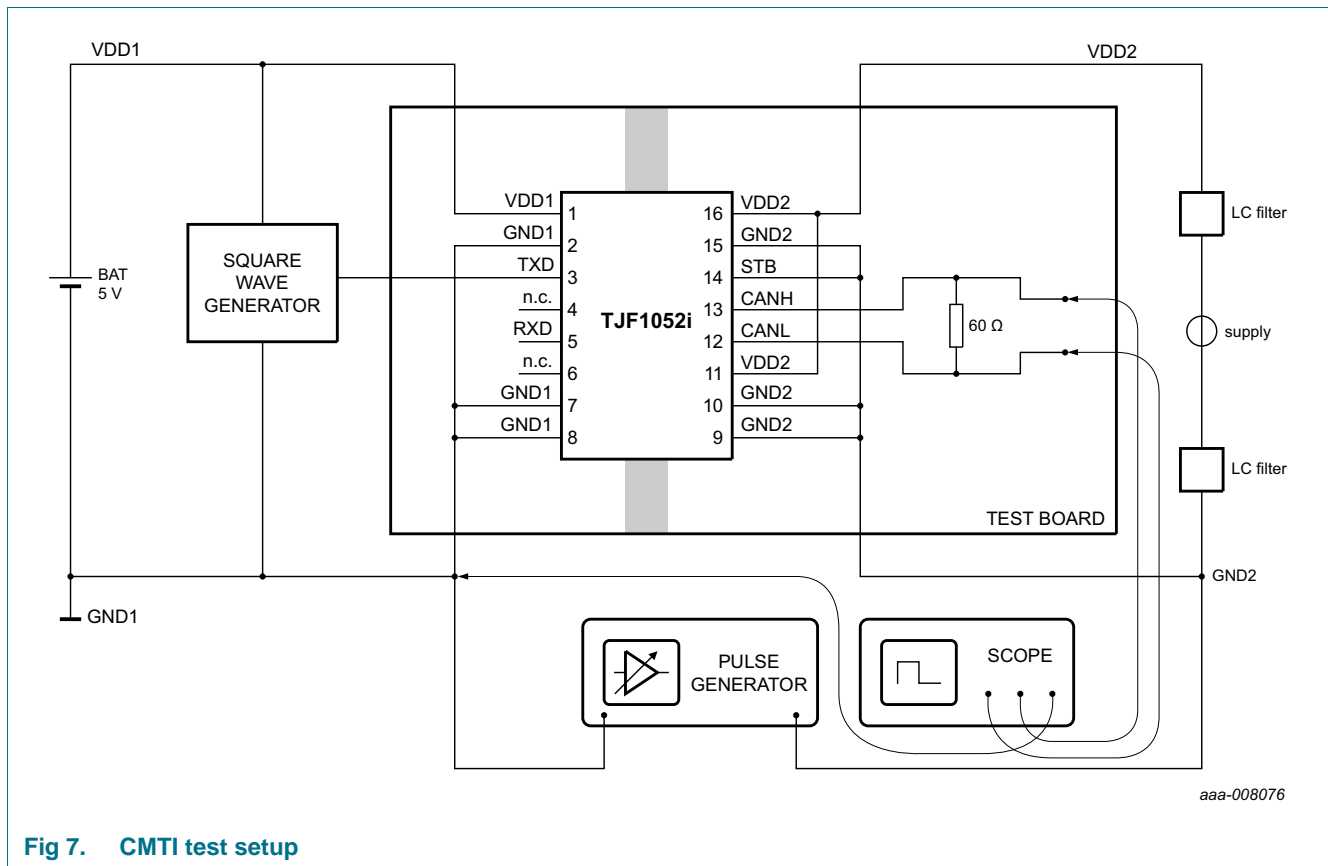

Fig 7. CMTI test setup

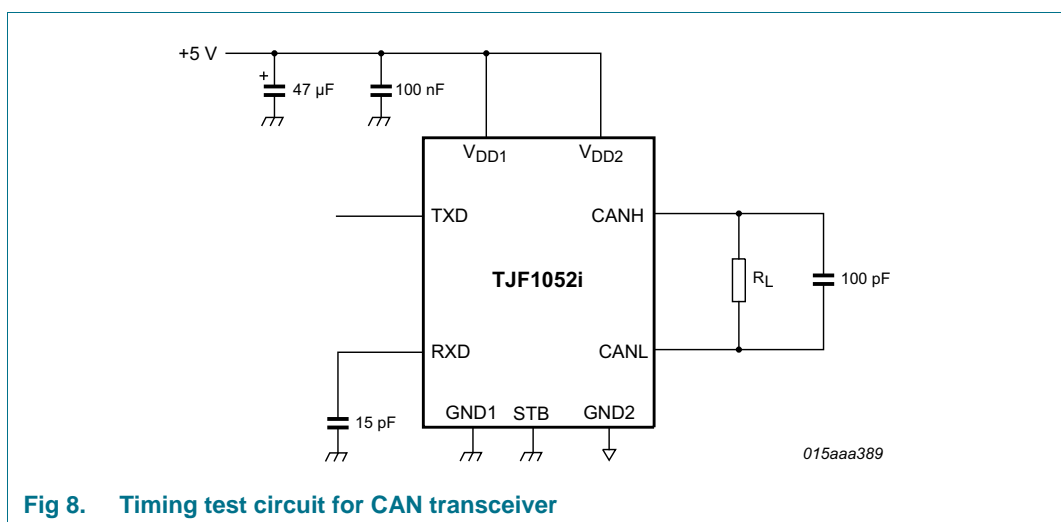
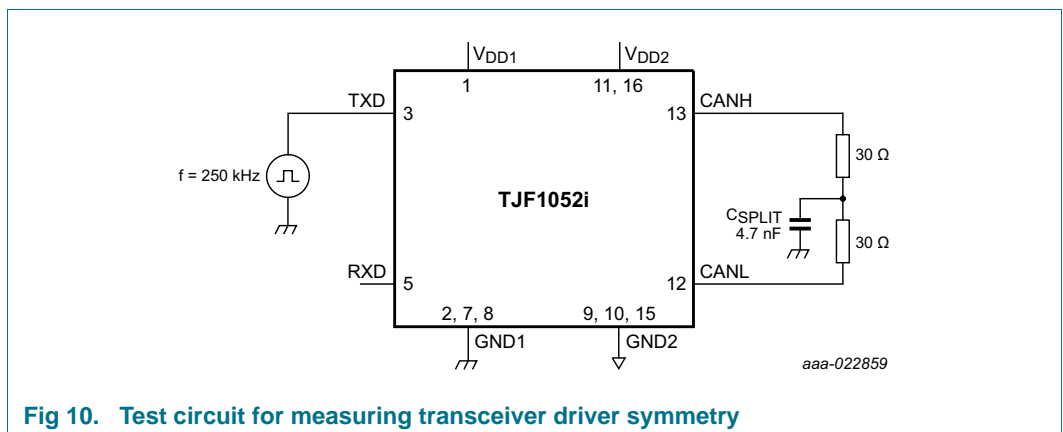
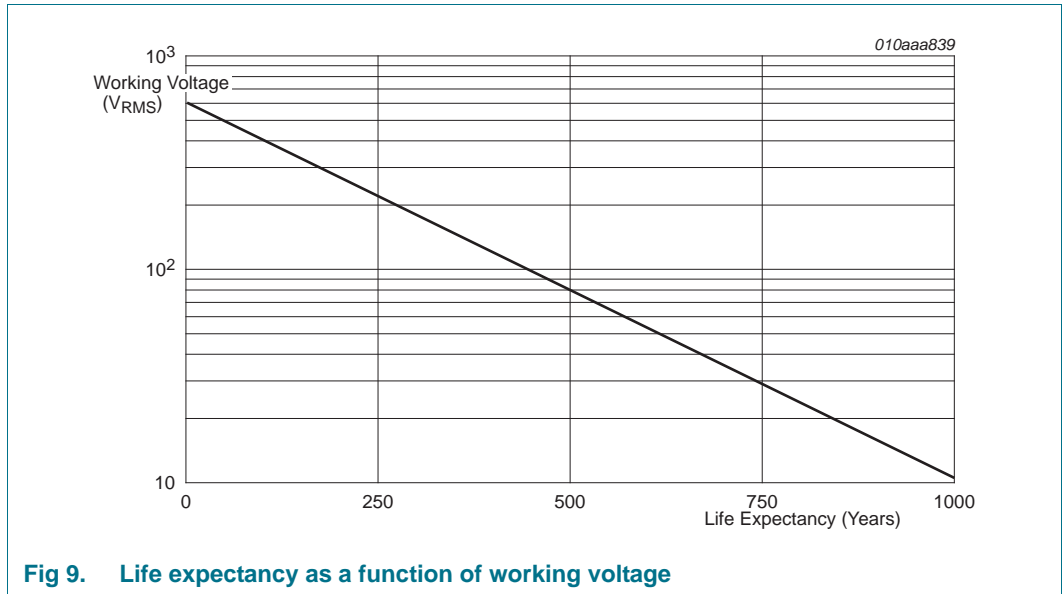

Fig 8. Timing test circuit for CAN transceiver



14. Package outline

SO16: plastic small outline package; 16 leads; body width 7.5 mm

SOT162-1

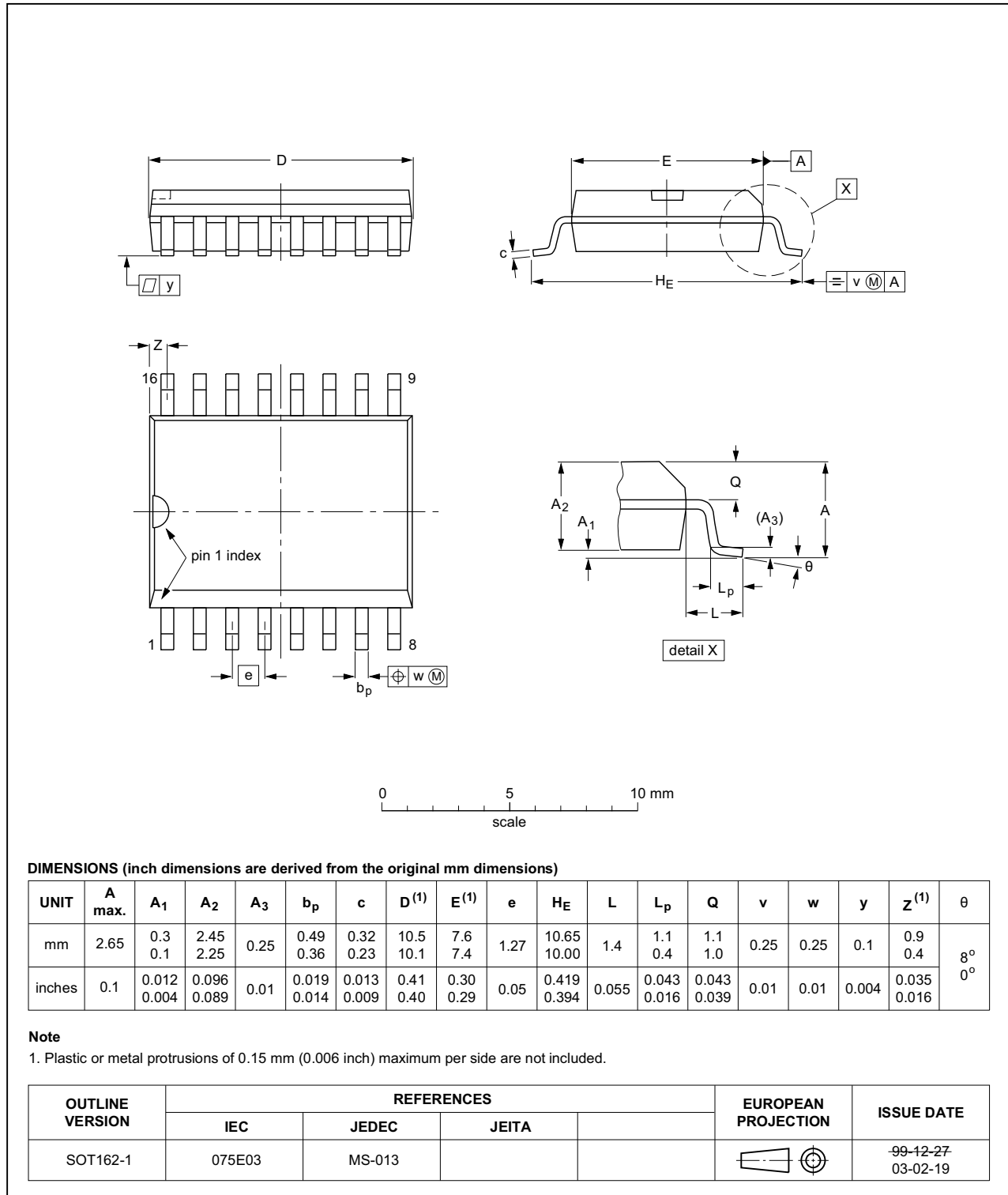

Fig 11. Package outline SOT162-1 (SO16)

15. Handling information

All input and output pins are protected against ElectroStatic Discharge (ESD) under normal handling. When handling ensure that the appropriate precautions are taken as described in *JESD625-A* or equivalent standards.

16. Soldering of SMD packages

This text provides a very brief insight into a complex technology. A more in-depth account of soldering ICs can be found in Application Note *AN10365 "Surface mount reflow soldering description"*.

16.1 Introduction to soldering

Soldering is one of the most common methods through which packages are attached to Printed Circuit Boards (PCBs), to form electrical circuits. The soldered joint provides both the mechanical and the electrical connection. There is no single soldering method that is ideal for all IC packages. Wave soldering is often preferred when through-hole and Surface Mount Devices (SMDs) are mixed on one printed wiring board; however, it is not suitable for fine pitch SMDs. Reflow soldering is ideal for the small pitches and high densities that come with increased miniaturization.

16.2 Wave and reflow soldering

Wave soldering is a joining technology in which the joints are made by solder coming from a standing wave of liquid solder. The wave soldering process is suitable for the following:

- Through-hole components
- Leaded or leadless SMDs, which are glued to the surface of the printed circuit board

Not all SMDs can be wave soldered. Packages with solder balls, and some leadless packages which have solder lands underneath the body, cannot be wave soldered. Also, leaded SMDs with leads having a pitch smaller than ~0.6 mm cannot be wave soldered, due to an increased probability of bridging.

The reflow soldering process involves applying solder paste to a board, followed by component placement and exposure to a temperature profile. Leaded packages, packages with solder balls, and leadless packages are all reflow solderable.

Key characteristics in both wave and reflow soldering are:

- Board specifications, including the board finish, solder masks and vias
- Package footprints, including solder thieves and orientation
- The moisture sensitivity level of the packages
- Package placement
- Inspection and repair
- Lead-free soldering versus SnPb soldering

16.3 Wave soldering

Key characteristics in wave soldering are:

- Process issues, such as application of adhesive and flux, clinching of leads, board transport, the solder wave parameters, and the time during which components are exposed to the wave
- Solder bath specifications, including temperature and impurities

16.4 Reflow soldering

Key characteristics in reflow soldering are:

- Lead-free versus SnPb soldering; note that a lead-free reflow process usually leads to higher minimum peak temperatures (see [Figure 12](#)) than a SnPb process, thus reducing the process window
- Solder paste printing issues including smearing, release, and adjusting the process window for a mix of large and small components on one board
- Reflow temperature profile; this profile includes preheat, reflow (in which the board is heated to the peak temperature) and cooling down. It is imperative that the peak temperature is high enough for the solder to make reliable solder joints (a solder paste characteristic). In addition, the peak temperature must be low enough that the packages and/or boards are not damaged. The peak temperature of the package depends on package thickness and volume and is classified in accordance with [Table 13](#) and [14](#)

Table 13. SnPb eutectic process (from J-STD-020D)

Package thickness (mm)	Package reflow temperature (°C)	
	Volume (mm ³)	
	< 350	≥ 350
< 2.5	235	220
≥ 2.5	220	220

Table 14. Lead-free process (from J-STD-020D)

Package thickness (mm)	Package reflow temperature (°C)		
	Volume (mm ³)		
	< 350	350 to 2000	> 2000
< 1.6	260	260	260
1.6 to 2.5	260	250	245
> 2.5	250	245	245

Moisture sensitivity precautions, as indicated on the packing, must be respected at all times.

Studies have shown that small packages reach higher temperatures during reflow soldering, see [Figure 12](#).

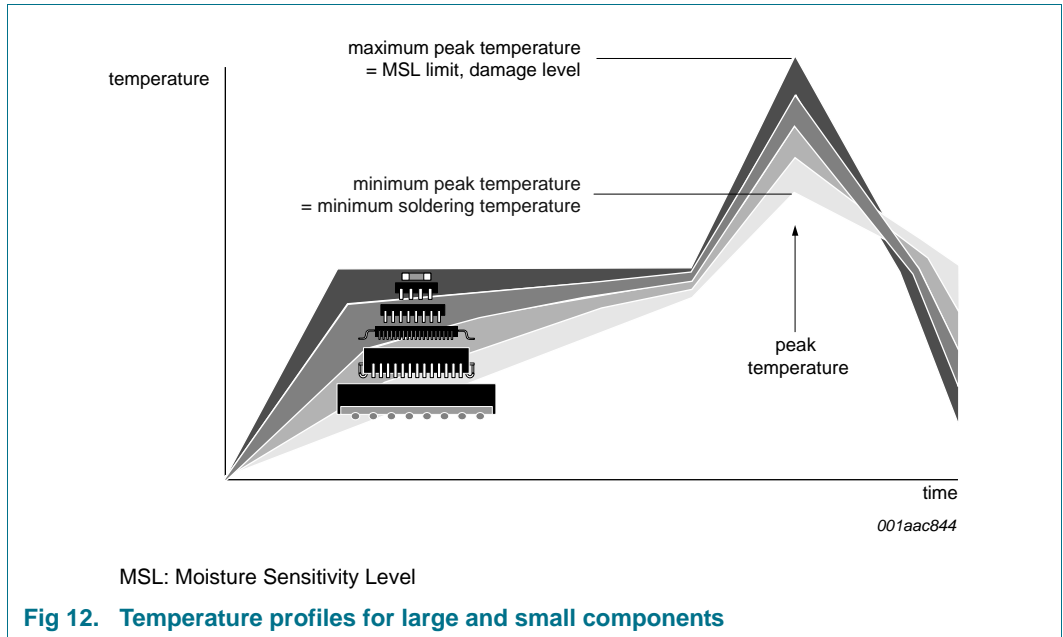

For further information on temperature profiles, refer to Application Note AN10365 “Surface mount reflow soldering description”.

17. Appendix: ISO 11898-2:2016 parameter cross-reference list

Table 15. ISO 11898-2:2016 to NXP data sheet parameter conversion

ISO 11898-2:2016		NXP data sheet	
Parameter	Notation	Symbol	Parameter
HS-PMA dominant output characteristics			
Single ended voltage on CAN_H	V_{CAN_H}	$V_{O(dom)}$	dominant output voltage
Single ended voltage on CAN_L	V_{CAN_L}		
Differential voltage on normal bus load	V_{Diff}	$V_{O(dif)}$	differential output voltage
Differential voltage on effective resistance during arbitration			
Optional: Differential voltage on extended bus load range			
HS-PMA driver symmetry			
Driver symmetry	V_{SYM}	V_{TXsym}	transmitter voltage symmetry
Maximum HS-PMA driver output current			
Absolute current on CAN_H	I_{CAN_H}	$I_{O(sc)dom}$	dominant short-circuit output current
Absolute current on CAN_L	I_{CAN_L}		
HS-PMA recessive output characteristics, bus biasing active/inactive			
Single ended output voltage on CAN_H	V_{CAN_H}	$V_{O(rec)}$	recessive output voltage
Single ended output voltage on CAN_L	V_{CAN_L}		
Differential output voltage	V_{Diff}	$V_{O(dif)}$	differential output voltage
Optional HS-PMA transmit dominant timeout			
Transmit dominant timeout, long	t_{dom}	$t_{to(dom)TXD}$	TXD dominant time-out time
Transmit dominant timeout, short			
HS-PMA static receiver input characteristics, bus biasing active/inactive			
Recessive state differential input voltage range	V_{Diff}	$V_{th(RX)dif}$	differential receiver threshold voltage
Dominant state differential input voltage range		$V_{rec(RX)}$	receiver recessive voltage
		$V_{dom(RX)}$	receiver dominant voltage
HS-PMA receiver input resistance (matching)			
Differential internal resistance	R_{Diff}	$R_{i(dif)}$	differential input resistance
Single ended internal resistance	R_{CAN_H} R_{CAN_L}	R_i	input resistance
Matching of internal resistance	MR	ΔR_i	input resistance deviation
HS-PMA implementation loop delay requirement			
Loop delay	t_{Loop}	$t_{d(TXDH-RXDH)}$	delay time from TXD HIGH to RXD HIGH
		$t_{d(TXDL-RXDL)}$	delay time from TXD LOW to RXD LOW
Optional HS-PMA implementation data signal timing requirements for use with bit rates above 1 Mbit/s up to 2 Mbit/s and above 2 Mbit/s up to 5 Mbit/s			
Transmitted recessive bit width @ 2 Mbit/s / @ 5 Mbit/s, intended	$t_{Bit(Bus)}$	$t_{bit(bus)}$	transmitted recessive bit width
Received recessive bit width @ 2 Mbit/s / @ 5 Mbit/s	$t_{Bit(RXD)}$	$t_{bit(RXD)}$	bit time on pin RXD
Receiver timing symmetry @ 2 Mbit/s / @ 5 Mbit/s	Δt_{Rec}	Δt_{rec}	receiver timing symmetry

Table 15. ISO 11898-2:2016 to NXP data sheet parameter conversion

ISO 11898-2:2016		NXP data sheet	
Parameter	Notation	Symbol	Parameter
HS-PMA maximum ratings of V_{CAN_H}, V_{CAN_L} and V_{Diff}			
Maximum rating V_{Diff}	V_{Diff}	$V_{(CANH-CANL)}$	voltage between pin CANH and pin CANL
General maximum rating V_{CAN_H} and V_{CAN_L}	V_{CAN_H}	V_x	voltage on pin x
Optional: Extended maximum rating V_{CAN_H} and V_{CAN_L}	V_{CAN_L}		
HS-PMA maximum leakage currents on CAN_H and CAN_L, unpowered			
Leakage current on CAN_H, CAN_L	I_{CAN_H} I_{CAN_L}	I_L	leakage current
HS-PMA bus biasing control timings			
CAN activity filter time, long	t_{Filter}	$t_{wake(busdom)}$ ^[1]	bus dominant wake-up time
CAN activity filter time, short		$t_{wake(busrec)}$ ^[1]	bus recessive wake-up time
Wake-up timeout, short	t_{Wake}	$t_{to(wake)bus}$	bus wake-up time-out time
Wake-up timeout, long			
Timeout for bus inactivity	$t_{Silence}$	$t_{to(silence)}$	bus silence time-out time
Bus Bias reaction time	t_{Bias}	$t_{d(busact-bias)}$	delay time from bus active to bias

[1] $t_{filtr(wake)bus}$ - bus wake-up filter time, in devices with basic wake-up functionality

18. Revision history

Table 16. Revision history

Document ID	Release date	Data sheet status	Change notice	Supersedes
TJF1052i v.3	20160520	Product data sheet	-	TJF1052i v.3
Modifications:	<ul style="list-style-type: none"> • Some minor typos and formatting errors corrected • Figure 1, Figure 4, Figure 6, Figure 8 amended • Section 7.1.2, Section 7.2.2 revised • Table 9: supply pin voltages combined in parameter V_x; Table note 1 added; parameter V_{tt} revised • Table 11: measurement added/values and conditions changed for parameter I_{DD2}; reference to Table note 2 added in measurement conditions of $I_{O(sc)dom}$; Table note 3 amended • Table 12: added parameter $t_{ftr(wake)bus}$ • ISO 11898-2:2016 compliance: <ul style="list-style-type: none"> - Section 1: text amended (2nd last paragraph) - Section 2.1: text amended (3rd feature) - Table 9: parameter $V_{(CANH-CANL)}$ added - Table 11: <ul style="list-style-type: none"> - measurement conditions changed for parameters $V_{O(dom)}$, $V_{O(dif)}$, I_L, $I_{O(sc)dom}$, $V_{hys(RX)dif}$ and $V_{th(RX)dif}$ (associated table note removed) - added parameters V_{TXsym} (and associated table note), $V_{rec(RX)}$ and $V_{dom(RX)}$ - symbol $V_{O(dif)bus}$ renamed as $V_{O(dif)}$ - additional measurements included for parameter $V_{O(dif)}$ - Table 12: <ul style="list-style-type: none"> - added parameters $t_{bit(bus)}$ and Δt_{rec} - parameter $t_{PD(TXD-RXD)}$ replaced with parameters $t_d(TXDL-RXDL)$ and $t_d(TXDH-RXDH)$ - additional measurement included for parameter $t_{bit(RXD)}$ - Figure 5 amended; Figure 10 added - Section 17 added 			
TJF1052i v.2	20150115	Product data sheet	-	TJF1052i v.1
TJF1052i v.1	201300710	Product data sheet	-	-

19. Legal information

19.1 Data sheet status

Document status ^{[1][2]}	Product status ^[3]	Definition
Objective [short] data sheet	Development	This document contains data from the objective specification for product development.
Preliminary [short] data sheet	Qualification	This document contains data from the preliminary specification.
Product [short] data sheet	Production	This document contains the product specification.

[1] Please consult the most recently issued document before initiating or completing a design.

[2] The term 'short data sheet' is explained in section "Definitions".

[3] The product status of device(s) described in this document may have changed since this document was published and may differ in case of multiple devices. The latest product status information is available on the Internet at URL <http://www.nxp.com>.

19.2 Definitions

Draft — The document is a draft version only. The content is still under internal review and subject to formal approval, which may result in modifications or additions. NXP Semiconductors does not give any representations or warranties as to the accuracy or completeness of information included herein and shall have no liability for the consequences of use of such information.

Short data sheet — A short data sheet is an extract from a full data sheet with the same product type number(s) and title. A short data sheet is intended for quick reference only and should not be relied upon to contain detailed and full information. For detailed and full information see the relevant full data sheet, which is available on request via the local NXP Semiconductors sales office. In case of any inconsistency or conflict with the short data sheet, the full data sheet shall prevail.

Product specification — The information and data provided in a Product data sheet shall define the specification of the product as agreed between NXP Semiconductors and its customer, unless NXP Semiconductors and customer have explicitly agreed otherwise in writing. In no event however, shall an agreement be valid in which the NXP Semiconductors product is deemed to offer functions and qualities beyond those described in the Product data sheet.

19.3 Disclaimers

Limited warranty and liability — Information in this document is believed to be accurate and reliable. However, NXP Semiconductors does not give any representations or warranties, expressed or implied, as to the accuracy or completeness of such information and shall have no liability for the consequences of use of such information. NXP Semiconductors takes no responsibility for the content in this document if provided by an information source outside of NXP Semiconductors.

In no event shall NXP Semiconductors be liable for any indirect, incidental, punitive, special or consequential damages (including - without limitation - lost profits, lost savings, business interruption, costs related to the removal or replacement of any products or rework charges) whether or not such damages are based on tort (including negligence), warranty, breach of contract or any other legal theory.

Notwithstanding any damages that customer might incur for any reason whatsoever, NXP Semiconductors' aggregate and cumulative liability towards customer for the products described herein shall be limited in accordance with the *Terms and conditions of commercial sale* of NXP Semiconductors.

Right to make changes — NXP Semiconductors reserves the right to make changes to information published in this document, including without limitation specifications and product descriptions, at any time and without notice. This document supersedes and replaces all information supplied prior to the publication hereof.

Suitability for use — NXP Semiconductors products are not designed, authorized or warranted to be suitable for use in life support, life-critical or safety-critical systems or equipment, nor in applications where failure or malfunction of an NXP Semiconductors product can reasonably be expected to result in personal injury, death or severe property or environmental damage. NXP Semiconductors and its suppliers accept no liability for inclusion and/or use of NXP Semiconductors products in such equipment or applications and therefore such inclusion and/or use is at the customer's own risk.

Applications — Applications that are described herein for any of these products are for illustrative purposes only. NXP Semiconductors makes no representation or warranty that such applications will be suitable for the specified use without further testing or modification.

Customers are responsible for the design and operation of their applications and products using NXP Semiconductors products, and NXP Semiconductors accepts no liability for any assistance with applications or customer product design. It is customer's sole responsibility to determine whether the NXP Semiconductors product is suitable and fit for the customer's applications and products planned, as well as for the planned application and use of customer's third party customer(s). Customers should provide appropriate design and operating safeguards to minimize the risks associated with their applications and products.

NXP Semiconductors does not accept any liability related to any default, damage, costs or problem which is based on any weakness or default in the customer's applications or products, or the application or use by customer's third party customer(s). Customer is responsible for doing all necessary testing for the customer's applications and products using NXP Semiconductors products in order to avoid a default of the applications and the products or of the application or use by customer's third party customer(s). NXP does not accept any liability in this respect.

Limiting values — Stress above one or more limiting values (as defined in the Absolute Maximum Ratings System of IEC 60134) will cause permanent damage to the device. Limiting values are stress ratings only and (proper) operation of the device at these or any other conditions above those given in the Recommended operating conditions section (if present) or the Characteristics sections of this document is not warranted. Constant or repeated exposure to limiting values will permanently and irreversibly affect the quality and reliability of the device.

Terms and conditions of commercial sale — NXP Semiconductors products are sold subject to the general terms and conditions of commercial sale, as published at <http://www.nxp.com/profile/terms>, unless otherwise agreed in a valid written individual agreement. In case an individual agreement is concluded only the terms and conditions of the respective agreement shall apply. NXP Semiconductors hereby expressly objects to applying the customer's general terms and conditions with regard to the purchase of NXP Semiconductors products by customer.

No offer to sell or license — Nothing in this document may be interpreted or construed as an offer to sell products that is open for acceptance or the grant, conveyance or implication of any license under any copyrights, patents or other industrial or intellectual property rights.

Export control — This document as well as the item(s) described herein may be subject to export control regulations. Export might require a prior authorization from competent authorities.

Quick reference data — The Quick reference data is an extract of the product data given in the Limiting values and Characteristics sections of this document, and as such is not complete, exhaustive or legally binding.

Translations — A non-English (translated) version of a document is for reference only. The English version shall prevail in case of any discrepancy between the translated and English versions.

Non-automotive qualified products — Unless this data sheet expressly states that this specific NXP Semiconductors product is automotive qualified, the product is not suitable for automotive use. It is neither qualified nor tested in accordance with automotive testing or application requirements. NXP Semiconductors accepts no liability for inclusion and/or use of non-automotive qualified products in automotive equipment or applications.

In the event that customer uses the product for design-in and use in automotive applications to automotive specifications and standards, customer (a) shall use the product without NXP Semiconductors' warranty of the product for such automotive applications, use and specifications, and (b) whenever customer uses the product for automotive applications beyond NXP Semiconductors' specifications such use shall be solely at customer's own risk, and (c) customer fully indemnifies NXP Semiconductors for any liability, damages or failed product claims resulting from customer design and use of the product for automotive applications beyond NXP Semiconductors' standard warranty and NXP Semiconductors' product specifications.

19.4 Trademarks

Notice: All referenced brands, product names, service names and trademarks are the property of their respective owners.

20. Contact information

For more information, please visit: <http://www.nxp.com>

For sales office addresses, please send an email to: salesaddresses@nxp.com

21. Contents

1	General description	1	19.4	Trademarks	26
2	Features and benefits	1	20	Contact information	26
2.1	General	1	21	Contents	27
2.2	Power management	2			
2.3	Protection	2			
3	Quick reference data	2			
4	Ordering information	3			
5	Block diagram	3			
6	Pinning information	4			
6.1	Pinning	4			
6.2	Pin description	4			
7	Functional description	5			
7.1	Operation	5			
7.1.1	Normal mode	5			
7.1.2	Standby mode	5			
7.2	Fail-safe features	6			
7.2.1	TXD dominant time-out function	6			
7.2.2	Undervoltage protection: V_{DD2}	6			
7.2.3	Undervoltage protection: V_{DD1}	6			
7.2.4	Overtemperature protection	7			
7.3	Insulation characteristics and safety-related specifications	7			
8	Limiting values	9			
9	Thermal characteristics	10			
10	Static characteristics	10			
11	Dynamic characteristics	13			
12	Application information	15			
12.1	Application hints	15			
13	Test information	16			
13.1	Test circuits	16			
14	Package outline	18			
15	Handling information	19			
16	Soldering of SMD packages	19			
16.1	Introduction to soldering	19			
16.2	Wave and reflow soldering	19			
16.3	Wave soldering	19			
16.4	Reflow soldering	20			
17	Appendix: ISO 11898-2:2016 parameter cross-reference list	22			
18	Revision history	24			
19	Legal information	25			
19.1	Data sheet status	25			
19.2	Definitions	25			
19.3	Disclaimers	25			

Please be aware that important notices concerning this document and the product(s) described herein, have been included in section 'Legal information'.

© NXP Semiconductors N.V. 2016.

All rights reserved.

For more information, please visit: <http://www.nxp.com>

For sales office addresses, please send an email to: salesaddresses@nxp.com

Date of release: 20 May 2016

Document identifier: TJF1052I